

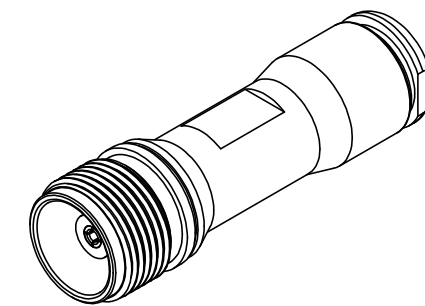

1608004N000-001

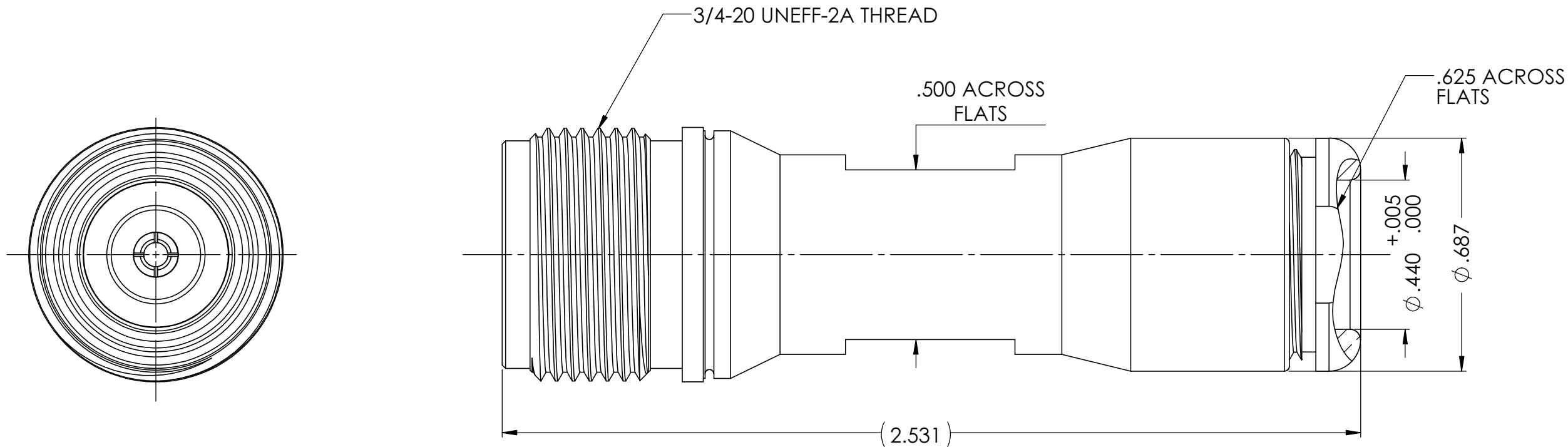

UG-60B/U, NI

NOTES:

- 1. ASSEMBLED CONNECTOR INTERFACE IS DESIGNED IN ACCORDANCE WITH MIL-STD-348.

CLAMP NUT	BRASS PER ASTM B16, C36000 ALLOY, TEMPER H02	NICKEL PLATE PER SAE-AMS-QQ-N-290
CLAMP	BRASS PER ASTM B16, C36000 ALLOY, TEMPER H02	NICKEL PLATE PER SAE-AMS-QQ-N-290
GASKET	SILICONE RUBBER PER A-A-59588	N/A
CLAMP	BRASS PER ASTM B16, C36000 ALLOY, TEMPER H02	NICKEL PLATE PER SAE-AMS-QQ-N-290
BODY	BRASS PER ASTM B16, C36000 ALLOY, TEMPER H02	NICKEL PLATE PER SAE-AMS-QQ-N-290
INSULATOR	TEFLON PER ASTM D1710, TYPE 1, GRADE 1, CLASS A.	N/A
CONTACT	BERYLLIUM COPPER PER ASTM B196, C17300, TEMPER TD04	SILVER PLATE PER ASTM B700
DESCRIPTION	MATERIAL	FINISH

Table 1

PROPRIETARY AND CONFIDENTIAL
 THE INFORMATION CONTAINED IN THIS DRAWING IS THE SOLE PROPERTY OF DELTA ELECTRONICS MFG CORP. ANY REPRODUCTION IN PART OR AS A WHOLE WITHOUT THE WRITTEN PERMISSION OF DELTA ELECTRONICS MFG CORP. IS PROHIBITED.
 FILE NAME: 1608004N000-001T

UNLESS OTHERWISE SPECIFIED:		NAME	DATE
DIMENSIONS ARE IN INCHES		DRAWN	ADK 4/28/2015
TOLERANCES:		CHECKED	ADK 4/28/2015
FRACTIONAL ± 1/64		ENG APPR.	BJM 4/28/2015
ANGULAR: MACH ± 1° BEND ± 1°		COMMENTS:	
TWO PLACE DECIMAL ±.01			
THREE PLACE DECIMAL ±.005			
SURFACE FINISH = 63			
MAX. CORNER BREAKS = .004			
THIRD ANGLE PROJECTION			
MATERIAL	SEE TABLE		
FINISH	SEE TABLE		
SCALE:			

DELTA ELECTRONICS MFG CORP. BEVERLY, MA 01915 www.deltarf.com / Ph: 978-927-1060 / Fax: 978-922-6430		
TITLE: HN STRAIGHT CLAMP JACK RG-8A, 9B, 87A, 213, 214, 225/U		
SIZE	DWG. NO.	REV
B	1608004N000-001	-
CODE ID - 00795	WEIGHT: 64.44 g	SHEET 1 OF 1